

Swirl Diffusers

with fixed air control blades

Type TDF-SilentAIR

recommended for room heights
from approx. 2.60 . . . 4.00 m

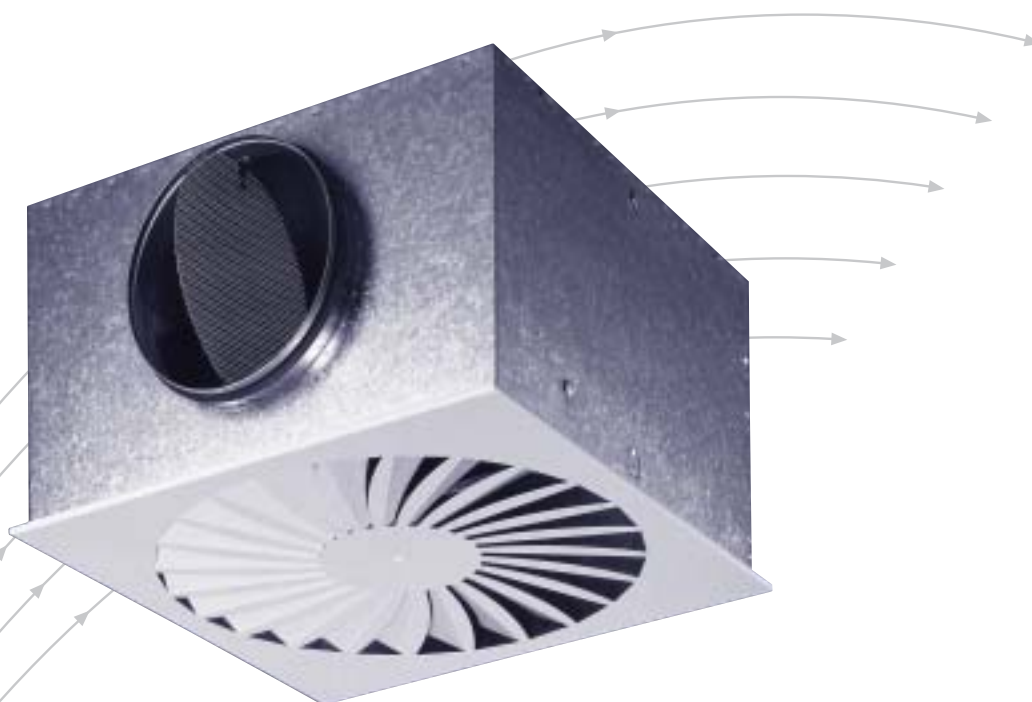

TROX[®] TECHNİK

TROX GmbH
Heinrich-Trox-Platz
D-47504 Neukirchen-Vluyn

Telephone +49/28 45/2 02-0
Telefax +49/28 45/2 02-2 65
e-mail trox@trox.de
www.troxtechnik.com

Contents · Description

Description _____	2	Quick Selection _____	5
Construction · Dimensions _____	3	Acoustic Data · Supply air _____	6
Materials · Installation · Assembly _____	4	Acoustic Data · Extract air _____	7
Weight _____	4	Aerodynamic Data _____	8
Nomenclature _____	5	Order Details _____	12

Type TDF-SilentAIR-Q

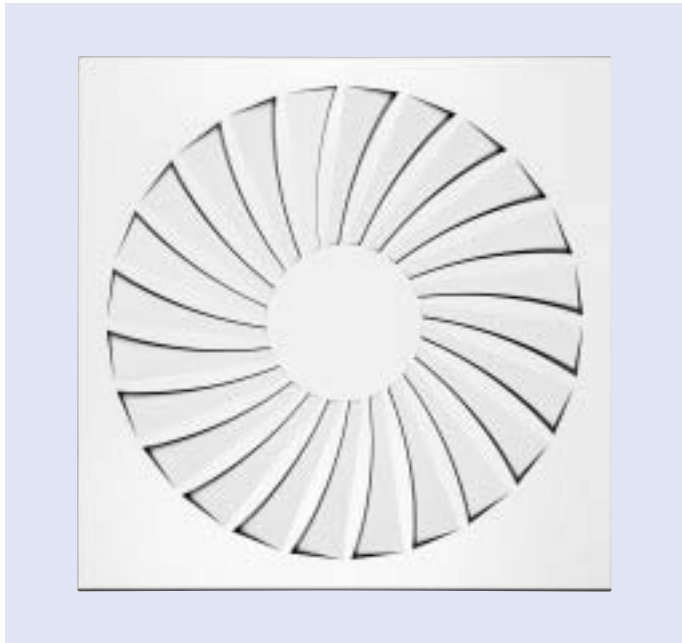

Type TDF-SilentAIR-R

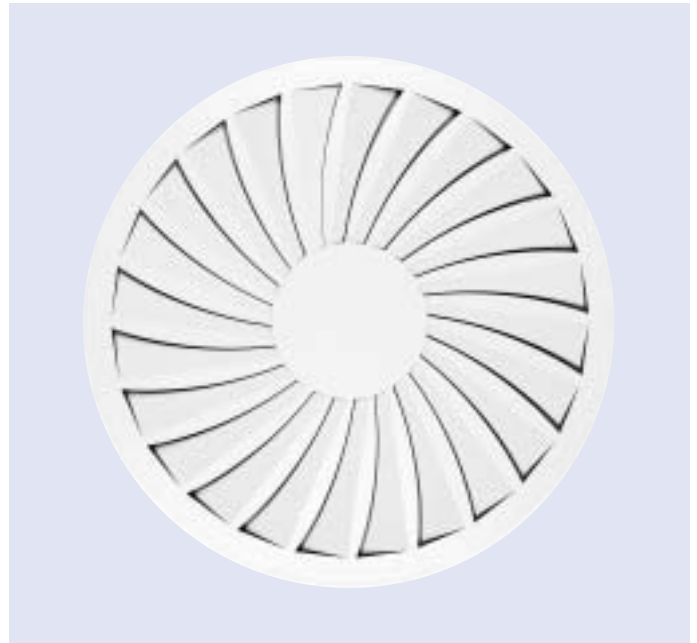

Type TDF SilentAIR swirl diffusers consist of fixed, radially arranged air control blades.

The diffuser face of the type TDF SilentAIR offers a high volume flow rate at low sound power levels. The horizontal swirl-type discharge of the supply air ensures high induction and hence rapid reduction in jet velocity and temperature differential. Suitable for supply air temperature differentials up to ± 10 °K.

All sizes must be installed flush with the ceiling to stabilise a horizontal discharge.

The minimum distance from the floor to the lower diffuser face should be 2.60 m.

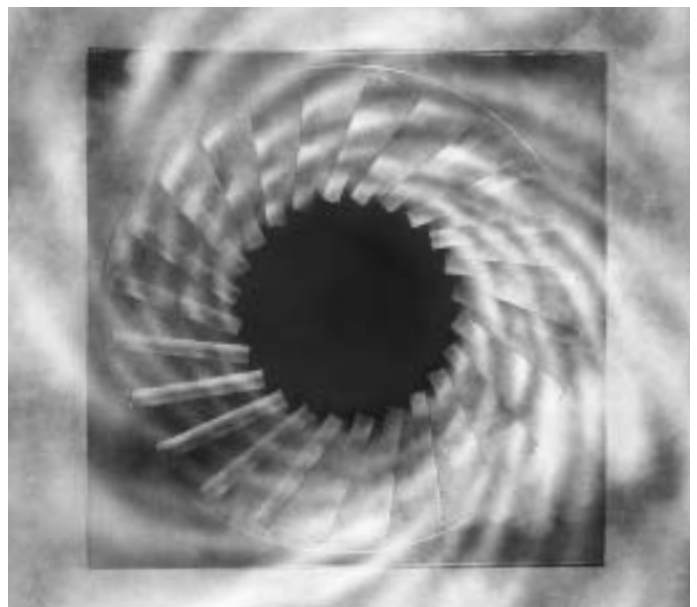

Flow pattern

Construction · Dimensions

Construction

TDF-SilentAIR swirl diffusers are available in five sizes to meet architectural requirements, the face plate can be circular or square. The fixed air control blades of the diffuser face are positioned radially. The diffuser face can be fixed to and removed from the plenum box by means of a central screw. The head of the fixing screw is covered by a decorative cap. The plenum box can be supplied with a top or side entry and upon request with a volume control damper and/or a lip seal. If a circular diffuser face is ordered, the plenum box with a side entry spigot has a 35 mm extension piece fitted to the plenum.

The plenum box with side entry spigot can be used with several Trox diffusers on the basis of the technical data.

Measuring the Reference Pressures

For simple adjustment of volume flow on request the plenum box can be provided with a test connection for measurement of a reference pressure and a volume control damper operated by sheathed cables. The characteristic curve of the pressure reading versus volume flow rate for each size of plenum box is supplied.

Size	Ø B	Ø D	Ø L	□ Q	Ø R	H ₂	□ K	Ø P	AK code ¹⁾	
									Square diffuser face	Circular diffuser face
300	280	158	254	298	300	250	290	278	AK001	AK013
400	364	198	336	398	400	295	372	362	AK002	AK014
500	462	198	440	498	500	295	476	460	AK003	AK015
600	559	248	530	598	600	345	567	557	AK004	AK016
625	559	248	530	623	625	345	567	557	AK004	AK016

1) Valid only for TDF-SilentAIR-...-H

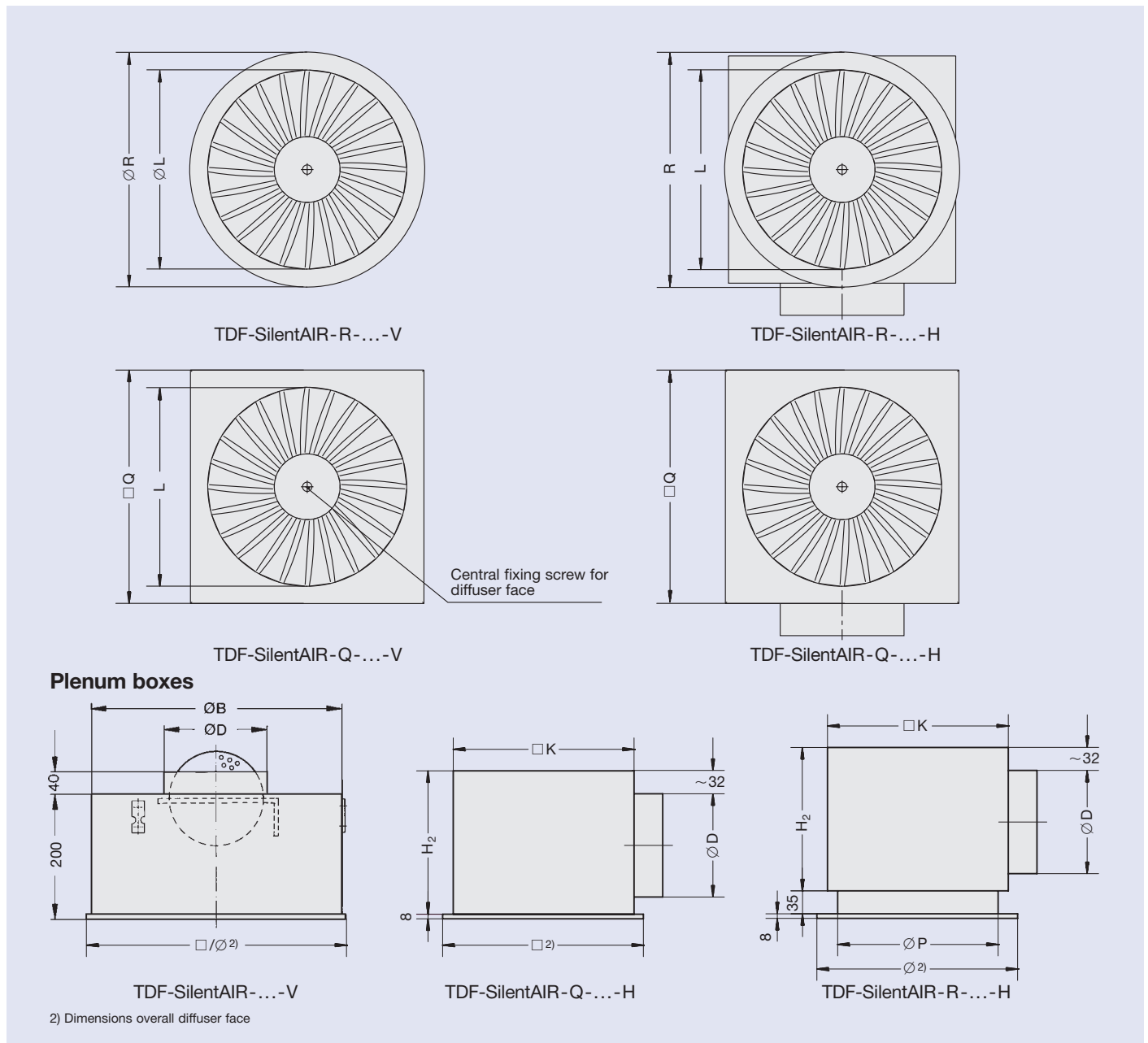

Materials · Installation · Assembly · Weights

Materials

The diffuser face is made of sendzimir galvanised sheet steel. The surface is pretreated and powder-coated "pure white" (RAL 9010). The plenum box is made of sendzimir galvanised sheet steel, the lip seal is of rubber.

Installation

All sizes are suitable for flush mounting into a ceiling. If the diffuser is installed below a closed ceiling (i.e., freely suspended) a stable discharge can be achieved if a peripheral collar > 50 mm is provided – available upon request.

Assembly

The plenum box is suspended by wires or slotted strips using the drilled holes in the plenum return edge or by hanging brackets when provided. For the side entry plenum box, a self adhesive seal, supplied loose, must be fitted by the client.

The diffuser face is fitted to the plenum box by means of a centre fix screw located in a cross channel in the plenum box.

Weights						
Size	Diffuser face		Plenumbox with side entry			
	square in kg	circular in kg	square AK no.	in kg	circular AK no.	in kg
300	0.7	0.6	AK001	~ 2.8	AK013	~ 3.2
400	1.3	1.0	AK002	~ 4.2	AK014	~ 4.8
500	2.0	1.6	AK003	~ 6.0	AK015	~ 6.5
600	3.2	2.3	AK004	~ 7.5	AK016	~ 8.0
625	3.5	2.5	AK004	~ 7.5	AK016	~ 8.0

Size	Plenumbox with top entry
300	2.0
400	3.0
500	4.0
600	5.5
625	7.0

Surface mounting on ceiling

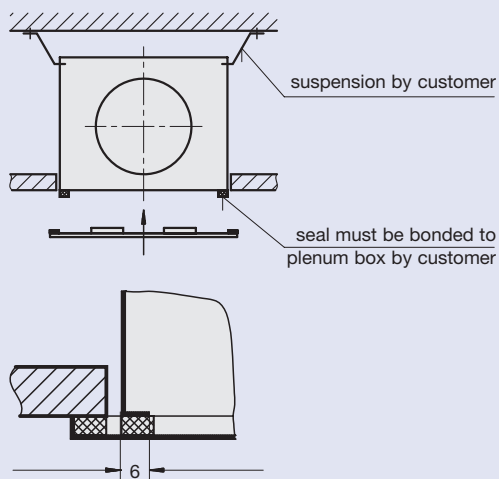

Fixing the diffuser face using centre screw

Freely suspended

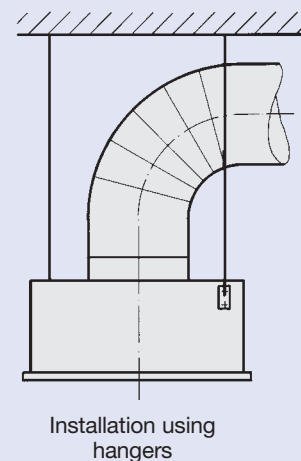

Installation flush to ceiling



Measuring the reference pressures

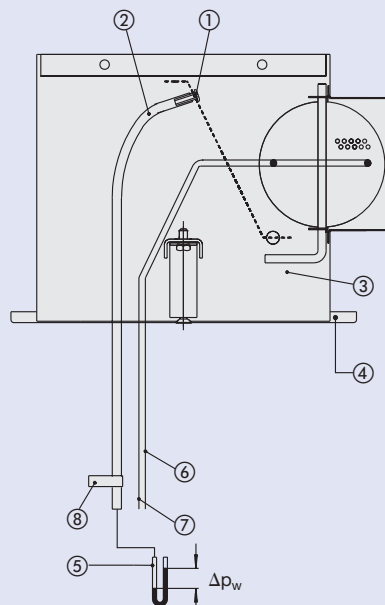

- ① Test nipple
- ② Plastic tube
- ③ Plenum box
- ④ Diffuser face
- ⑤ Inclined manometer
- ⑥ Green sheathed cable for closing the damper
- ⑦ White sheathed cable for opening the damper
- ⑧ Code

Nomenclature · Quick Selection Type TDF-SilentAIR

Nomenclature

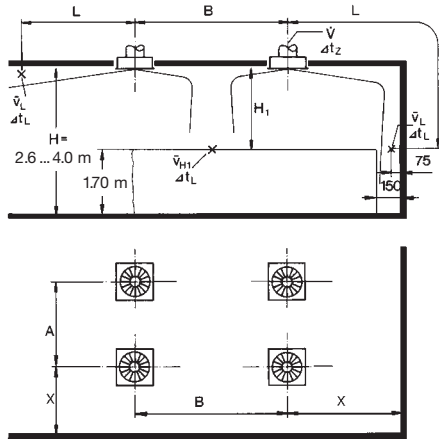

L_{pA} , L_{pNC} : A weighting or NC rating respectively of room sound pressure level $L_{pA} \approx L_{WA} - 8 \text{ dB}$
 $L_{pNC} \approx L_{WNC} - 8 \text{ dB}$

- $L_{0.5}/L_{0.3}$ in m: Throw referred to jet velocities of 0.3 m/s and 0.5 m/s respectively
- \dot{V} in l/s: Volume flow rate per diffuser
- \dot{V} in m^3/h : Volume flow rate per diffuser
- A, B in m: Spacing between two diffusers
- X in m: Distance between diffuser centre and wall
- H_1 in m: Distance between ceiling and occupied zone
- \bar{v}_{H1} in m/s: Time average air velocity between two diffusers at distance H_1 from ceiling
- Δt_z in K: Temperature difference between supply-air and room-air
- Δt_L in K: Differential between core and room temperatures at distance $L = A/2 + H_1$
or $L = B/2 + H_1$
or $L = X + H_1$
- A_{eff} in m^2 : Effective outlet area
- Δp_t in Pa: Total pressure drop (supply air)
- L_{WA} in dB(A): A weighted sound power level
- L_{WNC} : NC rating of sound power level
 $L_{WNC} = L_{WA} - 6 \text{ dB}$
- L_{WNR} : $L_{WNR} = L_{WNC} + 2$

Quick Selection

Size	A_{eff} m^2		\dot{V} (l/s)																
			\dot{V} m^3/h																
			30	50	70	100	125	150	180	200	250								
			108	180	252	360	450	540	648	720	900								
300	0.0108	$L_{0.5}/L_{0.3}$ in m	-	1.2	1.2	1.9	1.6	2.6	2.3	3.8									
		L_{WA} in dB(A)	23		35		45		57										
		Δp_t in Pa	10		28		54		111										
		\bar{v}_{H1} 1.2 m in m/s	-	< 0.1	0.11	0.11	0.16	0.16	0.25	0.24									
400	0.0193	$L_{0.5}/L_{0.3}$ in m				1.2	2.0	1.7	2.8	2.1	3.5	2.5	4.2						
		L_{WA} in dB(A)				26		36		42		47							
		Δp_t in Pa				15		30		47		67							
		\bar{v}_{H1} 1.2 m in m/s				0.12	0.12	0.18	0.18	0.23	0.23	0.28	0.25						
500	0.0280	$L_{0.5}/L_{0.3}$ in m				-	1.6	1.4	2.3	1.7	2.9	2.1	3.5	2.5	4.2				
		L_{WA} in dB(A)				19		29		36		41		46					
		Δp_t in Pa				9		19		29		42		60					
		\bar{v}_{H1} 1.2 m in m/s				-	0.10	0.15	0.15	0.18	0.18	0.23	0.23	0.28	0.25				
600/ 625	0.0400	$L_{0.5}/L_{0.3}$ in m						1.2	2.0	1.5	2.4	1.8	2.9	2.1	3.5	2.3	3.9	2.3	4.9
		L_{WA} in dB(A)						19		26		32		38		41		47	
		Δp_t in Pa						9		14		21		30		37		58	
		\bar{v}_{H1} 1.2 m in m/s						0.12	0.12	0.15	0.15	0.19	0.19	0.23	0.23	0.25	0.24	0.33	0.25

\bar{v}_{H1} referred to $A = L + H_1$, applicable to $B \geq 4.00 \text{ m}$
 L see table
 $H_1 = 1.2 \text{ m}$
 L_{WA} or Δp_t : with TDF-SilentAIR-Q-...-H

Acoustic Data

Supply Air

Correction to diagram 1: Volume control damper position

Size	Damper angle	0°	45°	90°
300	Δp_t	x 1.0	x 1.2	x 2.2
	L_{WA}/L_{WNC}	+ 0	+ 0	+ 0
400	Δp_t	x 1.0	x 1.2	x 2.8
	L_{WA}/L_{WNC}	+ 0	+ 0	+ 2.0
500	Δp_t	x 1.0	x 1.4	x 3.8
	L_{WA}/L_{WNC}	+ 0	+ 1.0	+ 5.0
600/625	Δp_t	x 1.0	x 1.3	x 3.2
	L_{WA}/L_{WNC}	+ 0	- 1.0	+ 4.0

Correction to diagram 2: Volume control damper position

Size	Damper angle	0°	45°	90°
300	Δp_t	x 1.0	x 1.2	x 2.2
	L_{WA}/L_{WNC}	+ 0	+ 0	+ 1.0
400	Δp_t	x 1.0	x 1.3	x 2.7
	L_{WA}/L_{WNC}	+ 0	+ 0	+ 2.0
500	Δp_t	x 1.0	x 1.3	x 4.0
	L_{WA}/L_{WNC}	+ 0	+ 0	+ 4.5
600/625	Δp_t	x 1.0	x 1.3	x 3.2
	L_{WA}/L_{WNC}	+ 0	+ 0	+ 2.5

1 TDF-SA-R-...-H

Sound power level and pressure drop

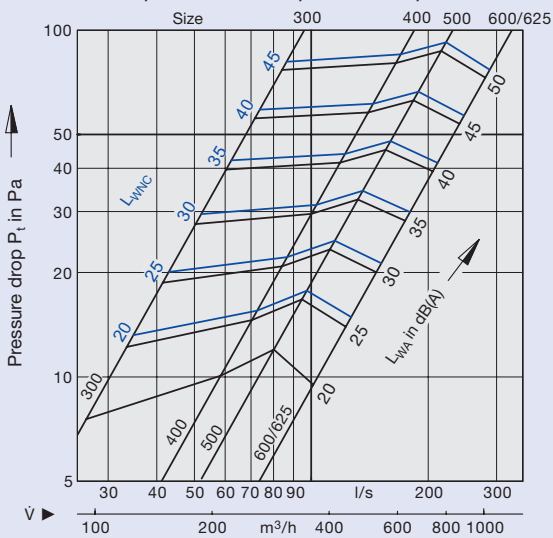

Correction to diagram 3: Volume control damper position

Size	Damper angle	0°	45°	90°
300	Δp_t	x 1.0	x 1.2	x 2.1
	L_{WA}/L_{WNC}	+ 0	+ 0	+ 0
400	Δp_t	x 1.0	x 1.3	x 2.8
	L_{WA}/L_{WNC}	+ 0	+ 1.0	+ 2.0
500	Δp_t	x 1.0	x 1.4	x 3.9
	L_{WA}/L_{WNC}	+ 0	+ 1.8	+ 5.0
600/625	Δp_t	x 1.0	x 1.4	x 3.1
	L_{WA}/L_{WNC}	+ 0	+ 2.0	+ 5.5

2 TDF-SA-Q-...-H

Sound power level and pressure drop

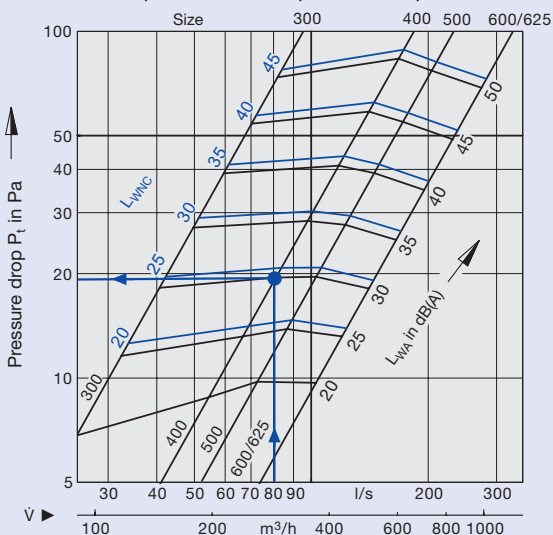

3 TDF-SA-...-V

Sound power level and pressure drop

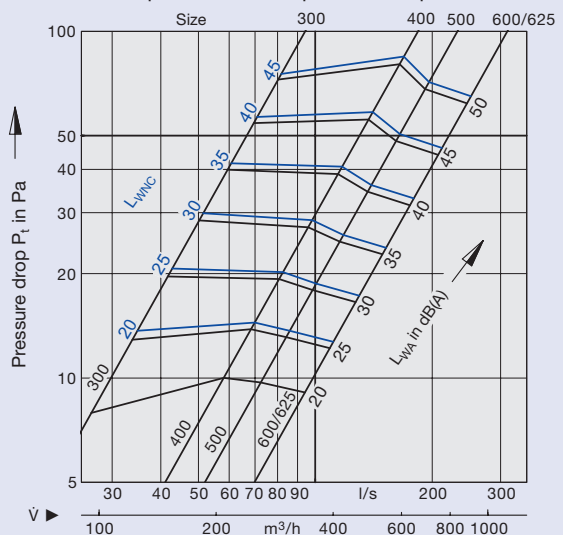

Correction to diagram 4: Volume control damper position

Size	Damper angle	0°	45°	90°
300	Δp_t	x 1.0	x 1.0	x 1.7
	L_{WA}/L_{WNC}	+ 0	+ 0	+ 2.0
400	Δp_t	x 1.0	x 1.2	x 2.4
	L_{WA}/L_{WNC}	+ 0	+ 0	+ 4.0
500	Δp_t	x 1.0	x 1.3	x 2.7
	L_{WA}/L_{WNC}	+ 0	+ 0	+ 6.0
600/625	Δp_t	x 1.0	x 1.1	x 2.3
	L_{WA}/L_{WNC}	+ 0	+ 0	+ 4.5

Correction to diagram 5: Volume control damper position

Size	Damper angle	0°	45°	90°
300	Δp_t	x 1.0	x 1.1	x 2.0
	L_{WA}/L_{WNC}	+ 0	+ 0	+ 2.0
400	Δp_t	x 1.0	x 1.2	x 2.9
	L_{WA}/L_{WNC}	+ 0	+ 0	+ 4.0
500	Δp_t	x 1.0	x 1.4	x 4.4
	L_{WA}/L_{WNC}	+ 0	+ 2.0	+ 9.0
600/625	Δp_t	x 1.0	x 1.2	x 3.3
	L_{WA}/L_{WNC}	+ 0	+ 1.0	+ 6.5

4 TDF-SA-...-V
Sound power level and pressure drop

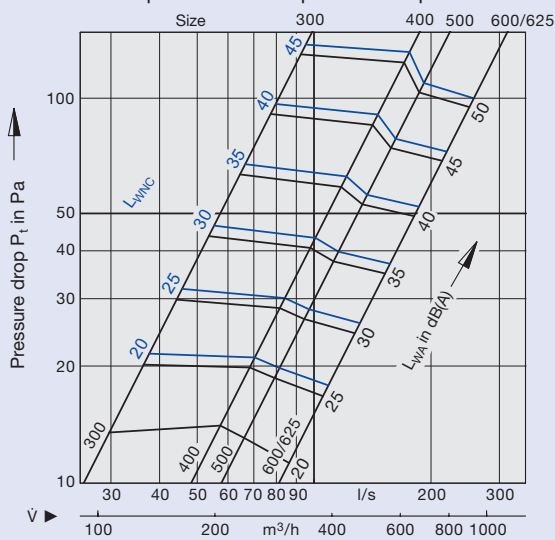

5 TDF-SA-...-H
Sound power level and pressure drop

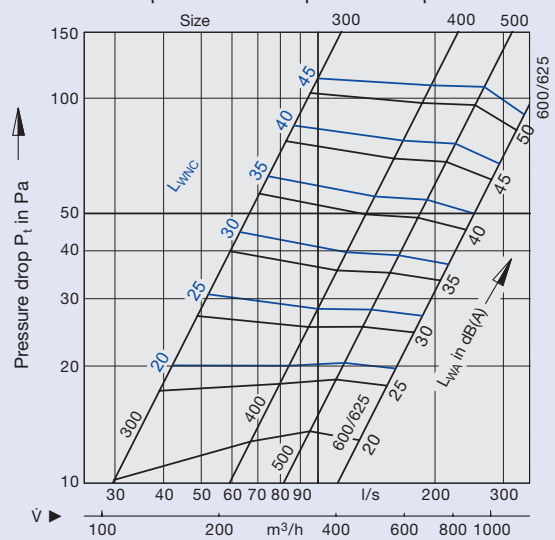

Aerodynamic Data TDF-SilentAIR

Size 300

Correction:

If the diffuser is installed below the ceiling values \bar{v}_{H1} and $\Delta t_L / \Delta t_z$ must be multiplied by 0.71!

6 Diffuser arrangement:
single-row or more than one row if $B \geq 4.00$ m
 $H_1 = 0.9 \quad 1.2 \quad 1.6 \quad 2$ m

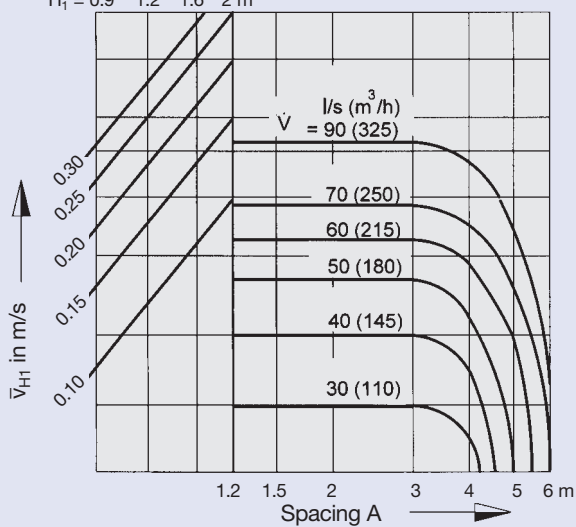

7 Diffuser arrangement
More than one row if $B = 3.00$ m
 $H_1 = 0.9 \quad 1.2 \quad 1.6 \quad 2$ m

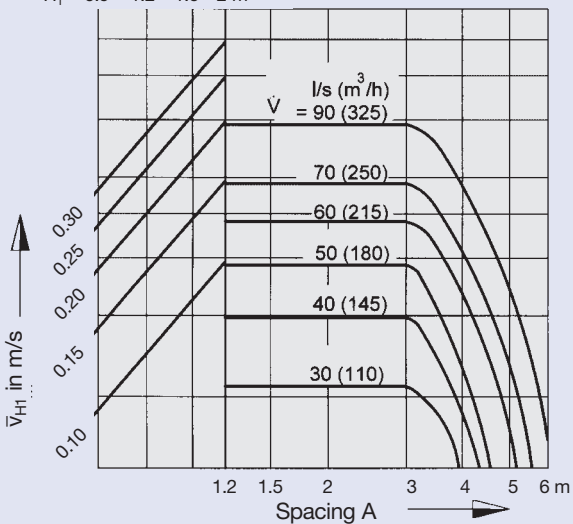

8 Temperature quotient

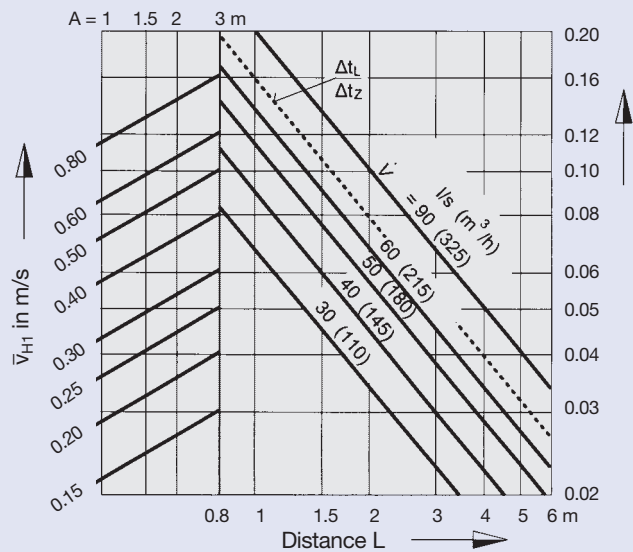

9 Square arrangement of diffusers

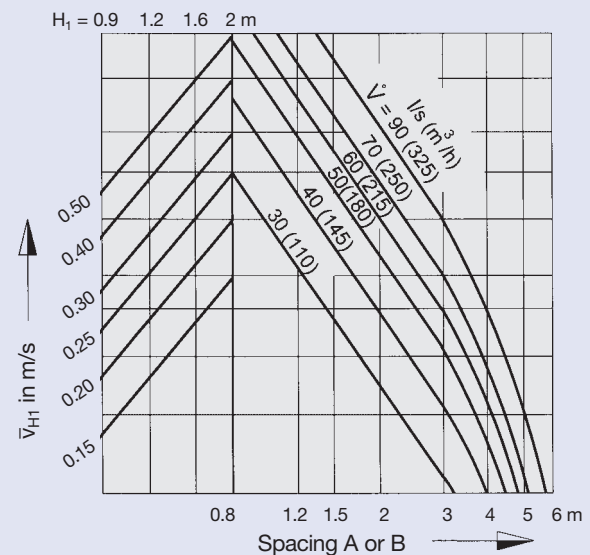

Example

Data given:
2 off Type TDF - SilentAIR - Q - H - Z / 400

Volume flow rate per diffuser $\dot{V} = 80 \text{ l/s}$
 Supply-air temperature differential $\Delta t_z = -8 \text{ K}$
 Spacing between two diffusers $A = 1.50 \text{ m}$
 Distance from diffuser centre to side wall $X = 1.50 \text{ m}$
 Distance from ceiling to occupied zone $H_1 = 1.20 \text{ m}$

Diagram 2: Sound power level and pressure drop

$L_{WA} = 30 \text{ dB(A)}$ ($L_{WNC} = 25 \text{ NC}$)
 $\Delta p_t = 19 \text{ Pa}$

Diagram 10: Diffuser arrangement single-row or more than one row

$\bar{v}_{H1} = 0.16 \text{ m/s}$

Diagram 12:

Temperature quotient

$$L = A/2 + H_1 = 0.75 + 1.20 = 1.95$$

$$\Delta t_L / \Delta t_z = 0.12$$

$$\Delta t_L = -8 \times 0.12 = -0.96 \text{ K} \quad \text{between two diffusers}$$

$$L = X + H_1 = 1.50 + 1.20 = 2.70 \text{ m}$$

$$\Delta t_L / \Delta t_z = 0.08$$

$$\Delta t_L = -8 \times 0.08 = -0.64 \text{ K} \quad \text{at the wall}$$

$$\bar{v}_L \approx 0.30 \text{ m/s}$$

Correction:

If the diffuser is installed below the ceiling values \bar{v}_{H1} , \bar{v}_L and $\Delta t_L / \Delta t_z$ must be multiplied by 0.71!

10 Diffuser arrangement:
single-row or more than one row if $B \geq 4.00 \text{ m}$
 $H_1 = 0.9 \ 1.2 \ 1.6 \ 2 \text{ m}$

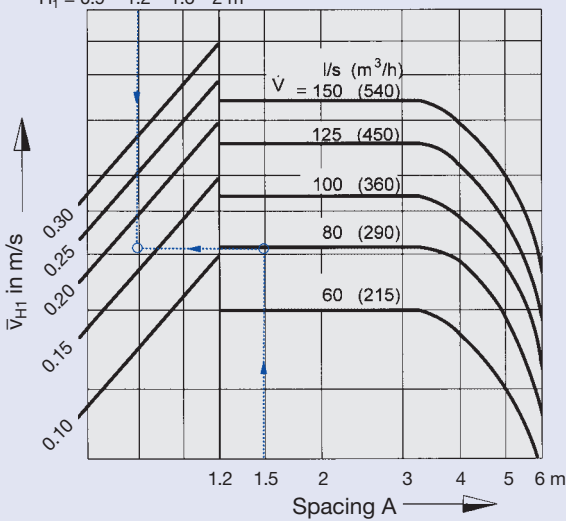

11 Diffuser arrangement:
More than one row if $B = 3.00 \text{ m}$
 $H_1 = 0.9 \ 1.2 \ 1.6 \ 2 \text{ m}$

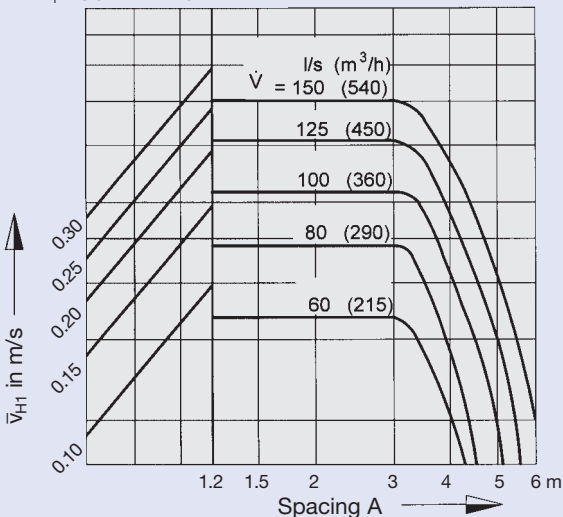

12 Temperature quotient

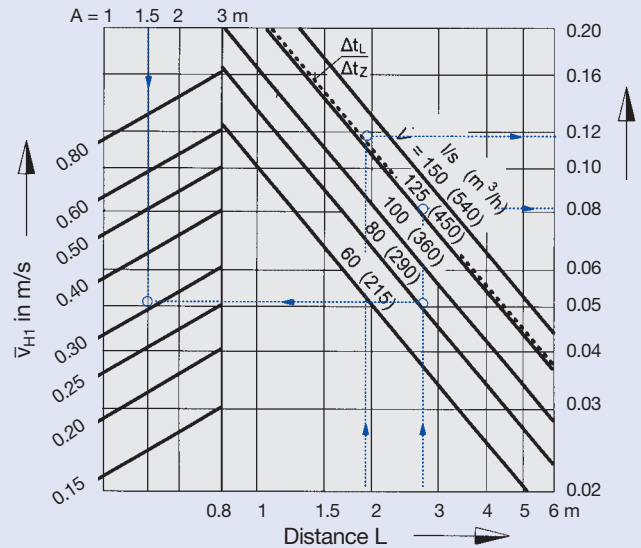

13 Square arrangement of diffusers

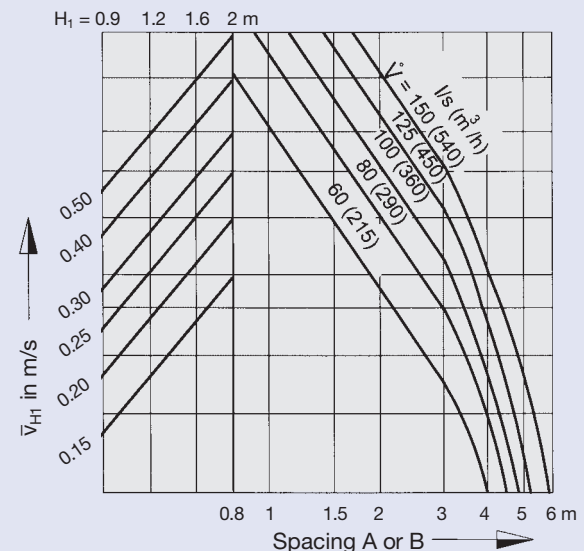

Aerodynamic Data TDF-SilentAIR

Size 500

Correction:

If the diffuser is installed below the ceiling values \bar{v}_{H1} , \bar{v}_L and $\Delta t_L / \Delta t_z$ must be multiplied by 0.71!

14 Diffuser arrangement:
single-row or more than one row if $B \geq 4.00$ m
 $H_1 = 0.9 \quad 1.2 \quad 1.6 \quad 2$ m

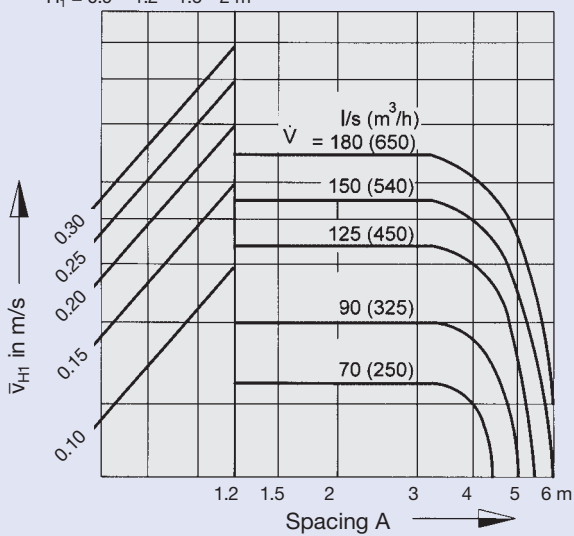

15 Diffuser arrangement:
More than one row if $B = 3.00$ m
 $H_1 = 0.9 \quad 1.2 \quad 1.6 \quad 2$ m

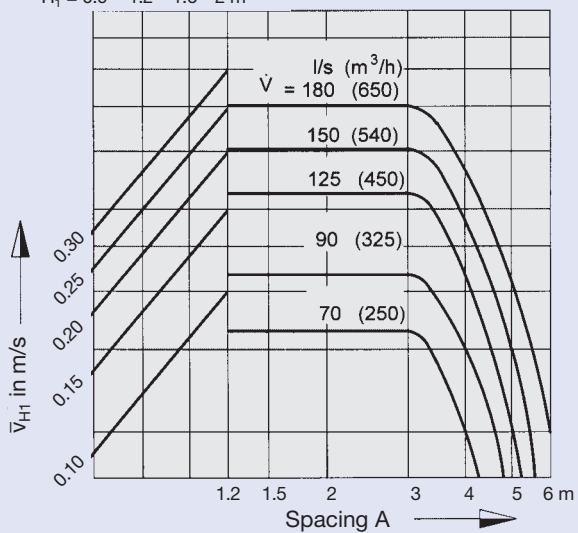

16 Temperature quotient

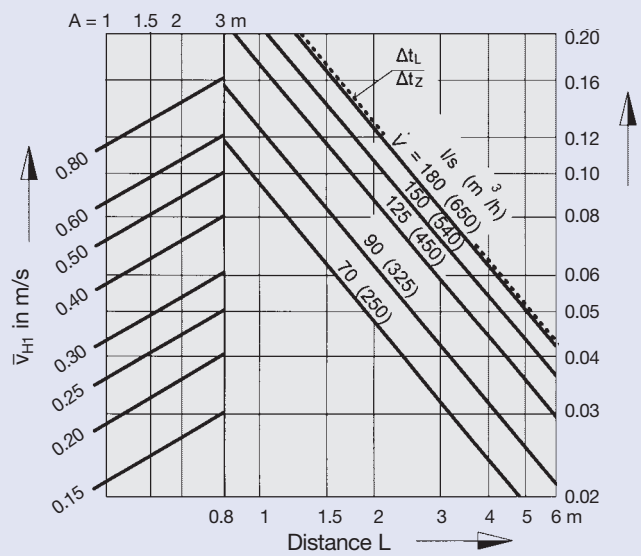

17 Square arrangement of diffusers

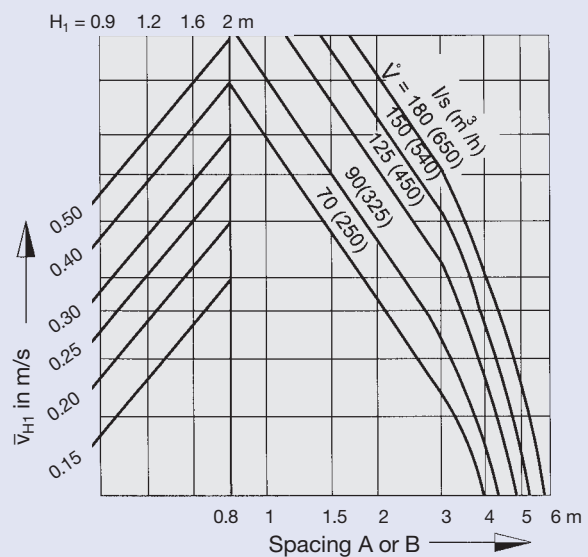

Aerodynamic Data TDF-SilentAIR

Size 600 and 625

Example

Data given:

4 off Type TDF - SilentAIR - Q - Z - H / 600

Volume flow rate per diffuser

$\dot{V} = 100 \text{ l/s}$

Spacing between two diffusers

$A = B = 2.00 \text{ m}$

Distance from ceiling to occupied zone

$H_1 = 160$

Required: Air velocity in the occupied zone

Diagram 21:

Square arrangement of diffusers

$\bar{v}_{H1} = 0.20 \text{ m/s}$

Correction:

If the diffuser is installed below the ceiling values \bar{v}_{H1} , \bar{v}_L and $\Delta t_L / \Delta t_z$ must be multiplied by 0.71!

18 Diffuser arrangement:
single-row or more than one row if $B \geq 4.00 \text{ m}$
 $H_1 = 0.9 \text{ 1.2 1.6 2 m}$

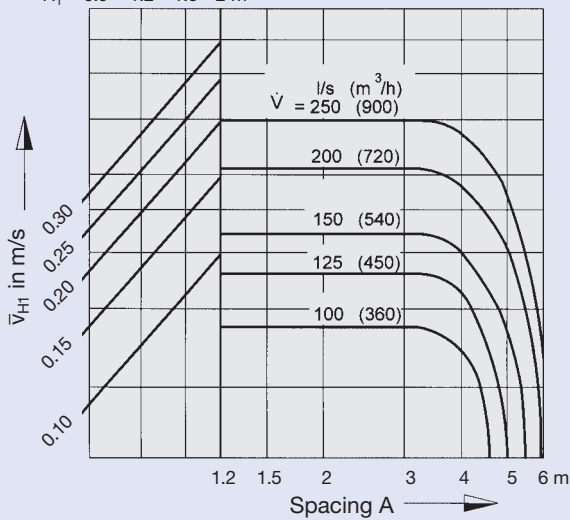

19 Diffuser arrangement:
More than one row if $B = 3.00 \text{ m}$
 $H_1 = 0.9 \text{ 1.2 1.6 2 m}$

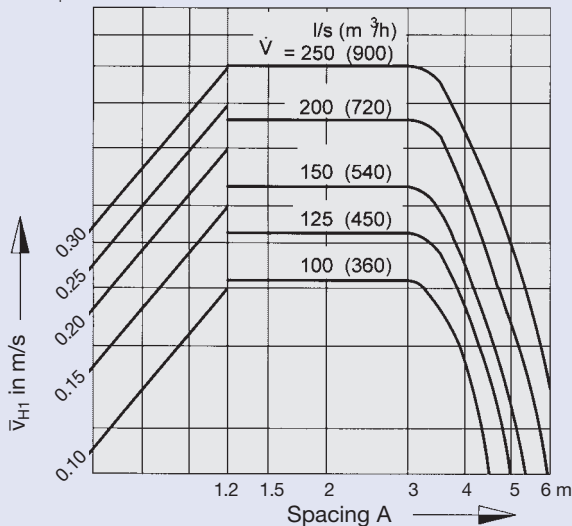

20 Temperature quotient

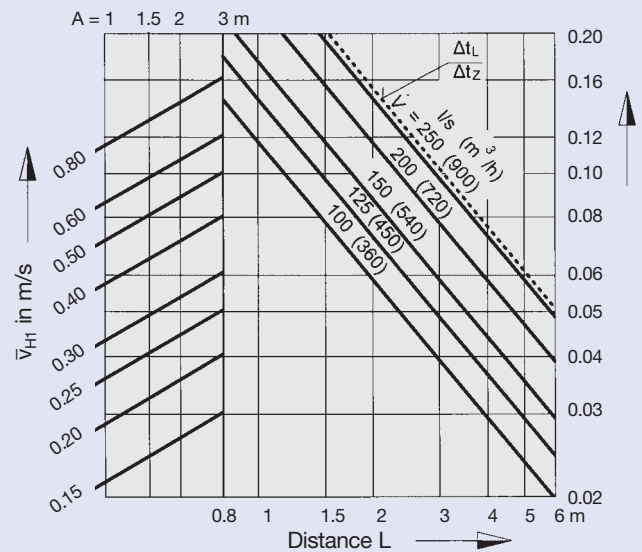

21 Square arrangement of diffusers

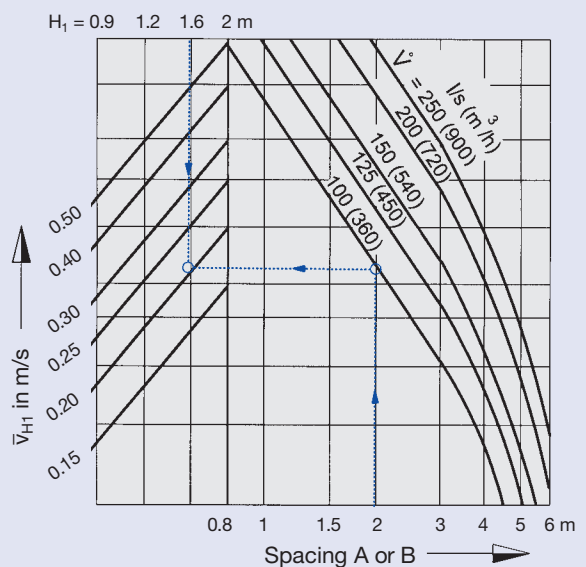

Order Details

Order Code

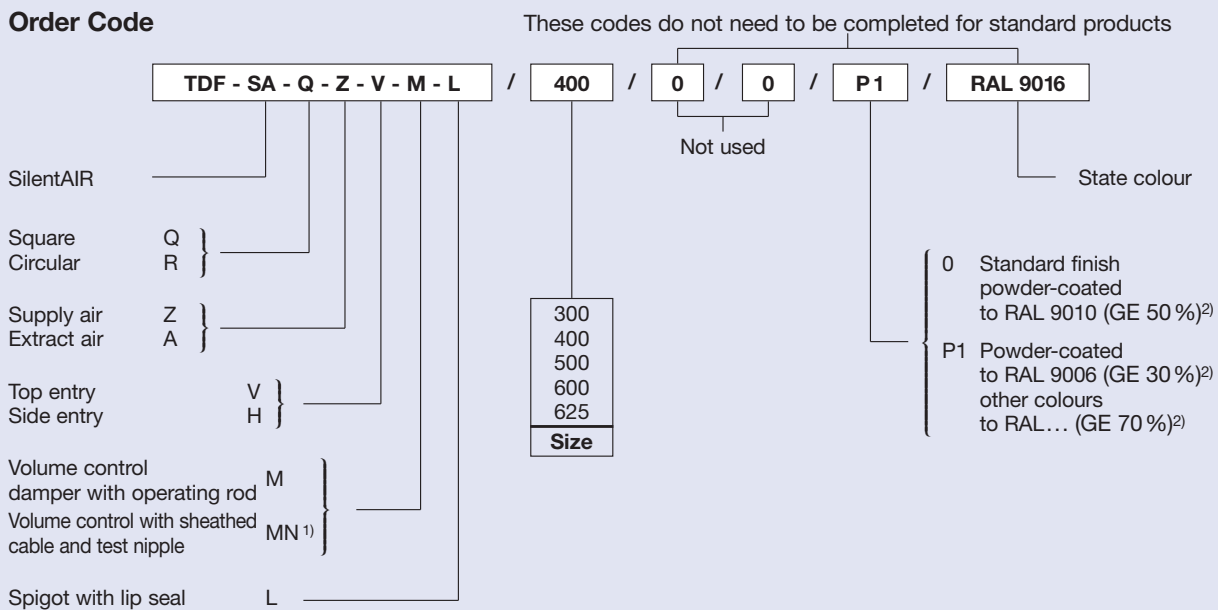

1) Only with horizontal connection!
2) GE = Gloss level

Specification Text

Type TDF-SilentAIR fixed blade swirl diffusers in circular or square construction for swirling horizontal discharge. Suitable for supply air temperature differentials up to ± 10 °K.

Consists of a diffuser face with radially arranged air control blades, and a rear plenum box with top or side entry spigots, optionally with volume control damper and/or lip seal.

On request to measure the reference pressure the plenum is fitted with a sheathed cable adjusted volume control damper and measuring nipple.

The plenum box with side entry circular spigot can be used with several Trox diffusers, provided the technical data is taken into account.

Materials:

The diffuser face is made of sendzimir galvanised sheet steel. The surface is pre-treated and powder-coated white (RAL 9010). The plenum box is made of sendzimir galvanised sheet steel, the lip seal of rubber.

Order Example

Make: TROX
Type: TDF - SA - Q - Z - V - M - L / 400 / P1 / RAL 9016