

Slot Diffuser

- Type VSD50
- with 50 mm wide diffuser face



TROX[®] TECHNİK

• TROX GmbH
• Heinrich-Trox-Platz
• D-47504 Neukirchen-Vluyn

Telephone +49/28 45/2 02-0
Telefax +49/28 45/2 02-2 65
e-mail trox@trox.de
www.troxtechnik.com

Contents · Air Diffuser Discharge

Air Diffuser Discharge _____	2	Spectral Data _____	9
Description _____	3	Acoustic Data _____	10
Construction · Dimensions _____	4	Aerodynamic Data _____	12
Installation Details _____	7	Order Details _____	16
Nomenclature _____	8		

**Air Discharge
Horizontal Right**

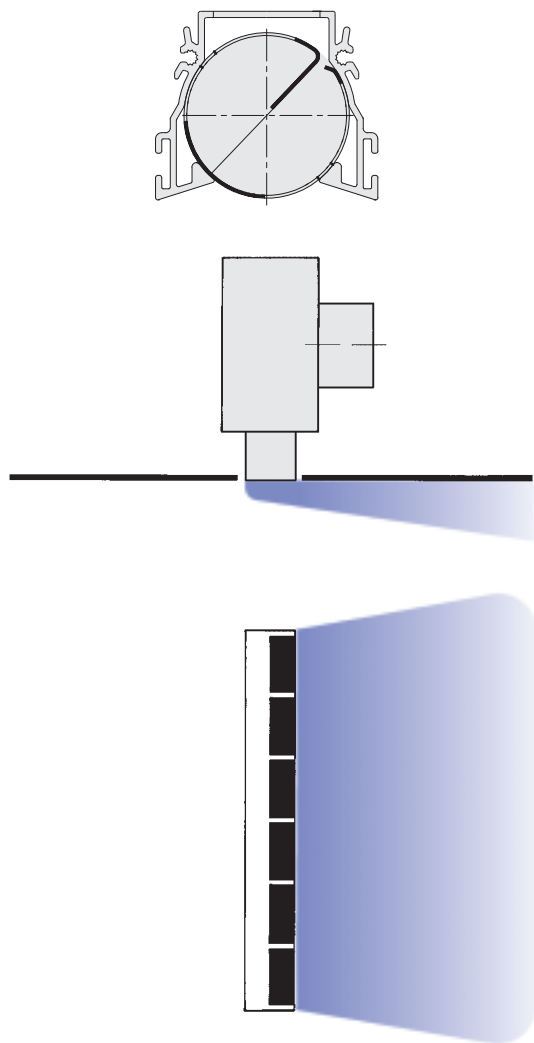

**Air Discharge
Horizontal Left**

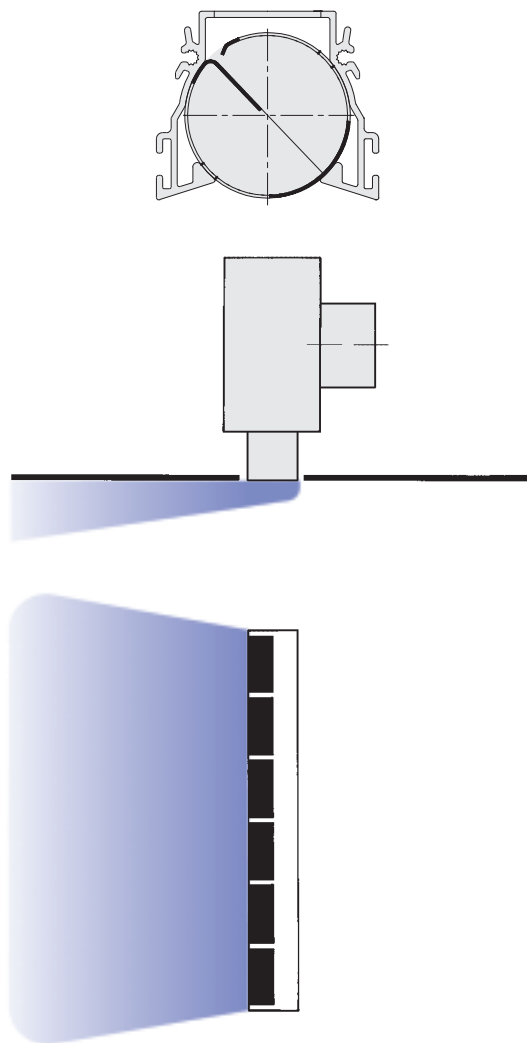

Description · Air Discharge

The type VSD50 slot diffuser is available with 1-2 slots. The diffuser face is a one piece extrusion, so there are no visible joints. The Type VSD50 can be used in rooms with heights from approx. 2.6 m to 4.0 m. The low overall height means that the slot diffusers are particularly suitable for use in restricted ceiling voids and in suspended ceiling systems. They are characterised by high induction which results in a rapid decrease in supply air temperature differential and jet velocity.

The recommended supply air temperature differential range is ± 10 K. Because of their stable discharge characteristics, the slot diffusers are suitable for use in systems with constant and variable volume flows.

The direction of air discharge can be adapted to the required room conditions. The air control blades are set at the factory to the customer's requirements as stated on the order. If the discharge directions have to be subsequently changed, this can easily be done on site by rotating the air control blades.

**Air Discharge
Alternating Angled**

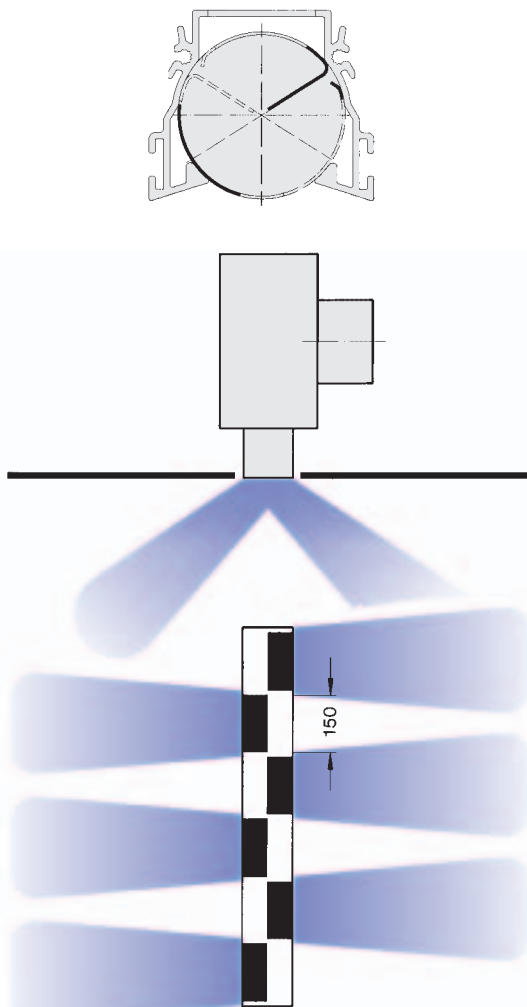

**Air Discharge
Alternating Horizontal**

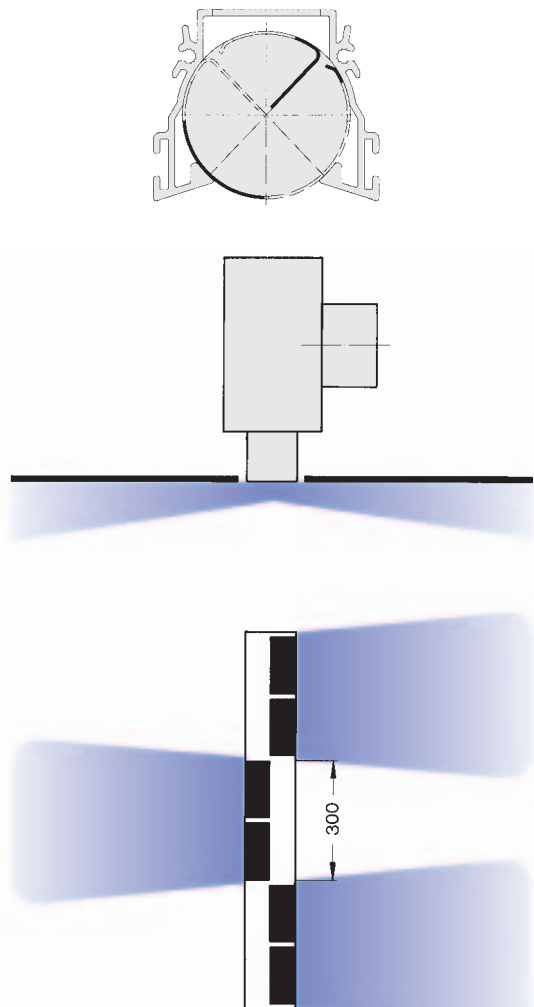

Construction · Dimensions

VSD50-...-AS; VSD50-...-DS with concealed bracket fixing									
No. of slots „n“	K ₁	K ₂	H ₁ ¹⁾	H ₂ ¹⁾	Q	∅ D	T ₁	T ₂	G
1	100	138	267	287	70	123	31	51	46
						158	14	34	48
2	138	176	307	327	112	158	34	54	48
						198	14	34	48

1) if y = 0 (Standard);
other possible values for y = 25, 50, 75 and 100 mm
maximum neck length 80 + y = 180 mm

VSD50-...-AK; VSD50-...-DK; VSD50-...-AA with clip fix										
No. of slots „n“	K ₃	K ₄	H ₃ ¹⁾	H ₄ ¹⁾	P	Q	∅ D	T ₁	T ₂	G
1	100	138	242	262	50	70	123	31	51	46
							158	14	34	48
2	138	176	282	302	92	112	158	34	54	48
							198	14	34	48

1) if y = 0 (Standard)
other possible values for y = 25, 50, 75, 100 and 125 mm
maximum neck length 55 + y = 180 mm

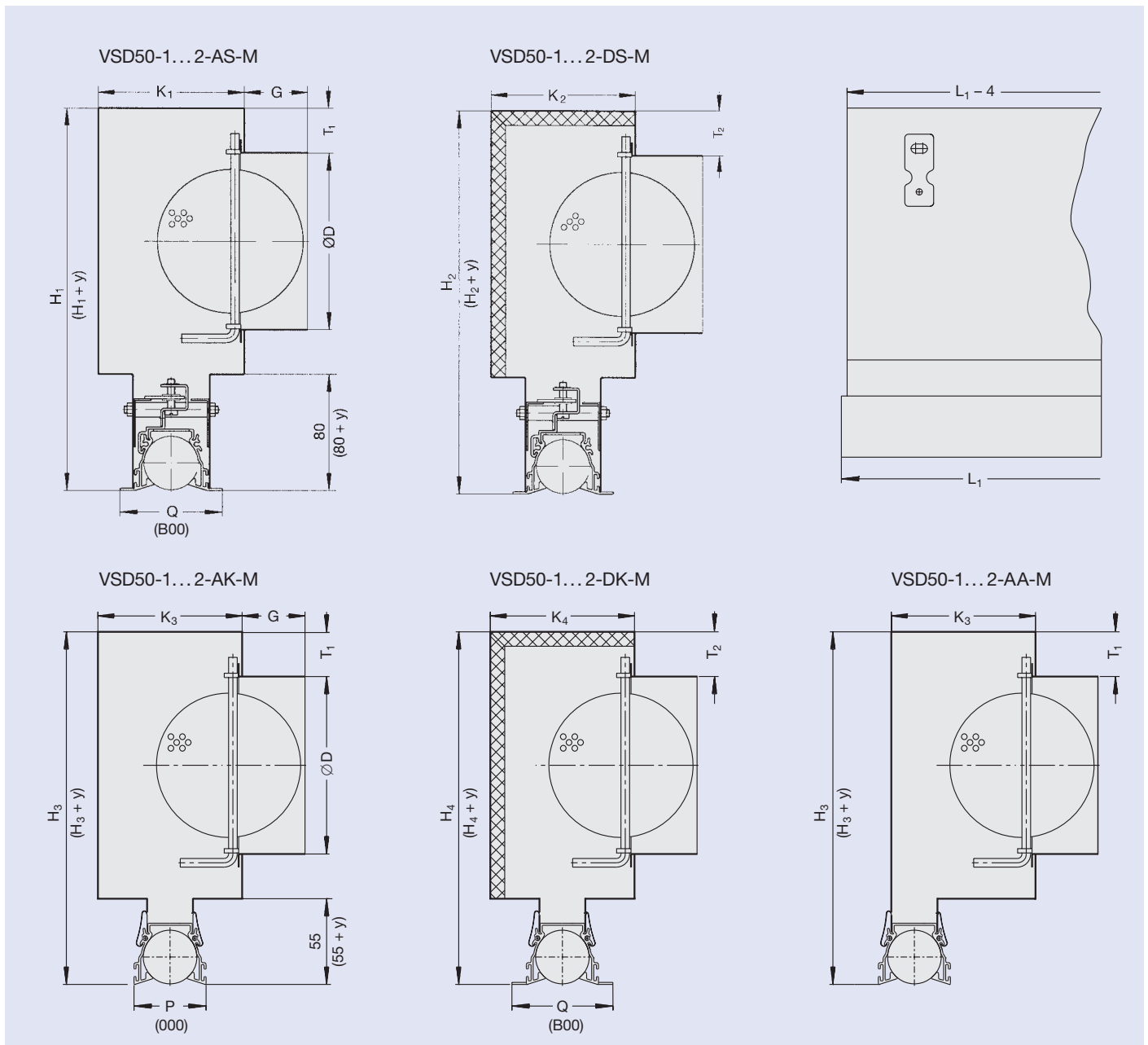

Construction · Dimensions

Number of spigots and spigot diameter		
L ₁	VSD50	
	...-1	...-2
600		
750		
900	1 x 123	1 x 158
1050	1 x 158	1 x 198
1200		
1350		
1500		
1650	2 x 123	2 x 158
1800	2 x 158	2 x 198
1950		

Variants AK, DK, and AA of the diffuser face are supplied with a plenum box fitted to the rear, while variant DK is provided with internal lining. On variants AS and DS, the face sections with flange B00 can be connected to the mounted plenum boxes on site. The supply air is connected via the circular side entry spigot, which is optionally available with a volume control damper which can be adjusted on the face of the diffuser.

The face sections are available without edge flange 000 or with integral edge flange B00. Matching end caps are available for the diffuser faces, in the form of end angles or end plates. The fish plates on the joints are also included in the scope of supply, to enable the alignment and inter-connection of individual L₁ sections.

Sections

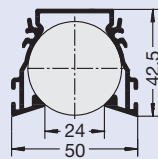

VSD50-1/000

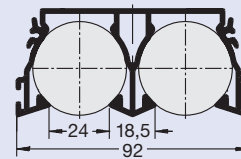

VSD50-2/000

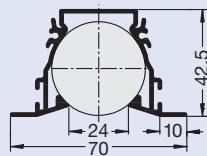

VSD50-1/B00

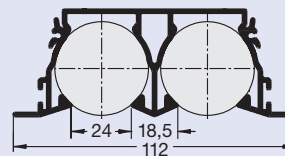

VSD50-2/B00

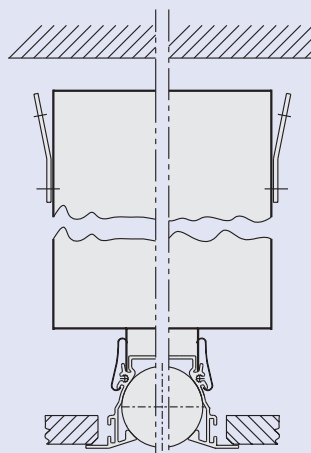

Installation in tiled ceilings

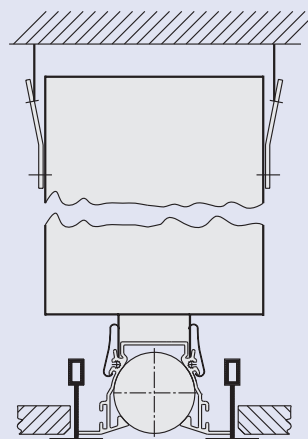

Installation in "T" bar ceilings

Construction · Dimensions

Without edge flange	000	end angle	1
Edge flange	B00	end angle	2
Without edge flange	000	end plate	3
Edge flange	B00	end plate	4

End caps



Without end cap



End cap on both ends

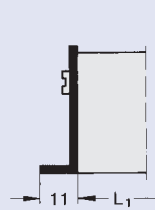

End angle

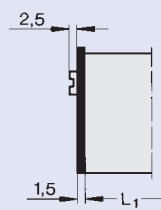

End plate

End angles

1 = for 000

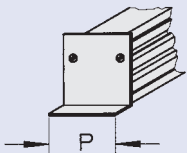

2 = for B00

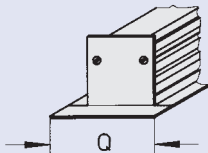

End plates

3 = for 000

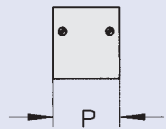

4 = for B00

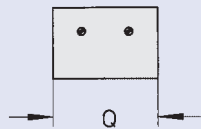

Alignment

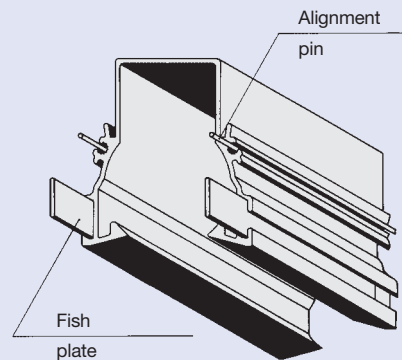

	E
VSD50/000	120
VSD50/B00	110

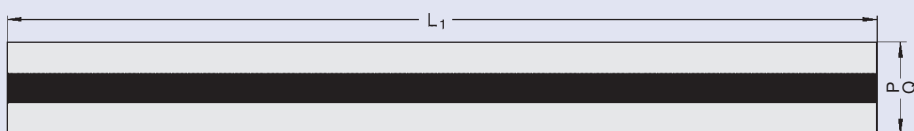

Front face "F"

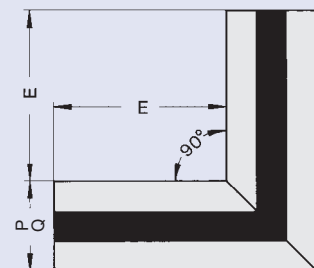

90° mitre

Installation Details

Figure 1

Standard method of installation for slot diffusers by suspension on four suspension points provided on the plenum box. Suitable installation and fixing materials to be provided on site.

Figure 2

In order to retrofit the diffuser face to the plenum box (AS, DS), the concealed fixing brackets which are supplied with the diffuser must be slid onto the face section. The tongue of the concealed fixing bracket must be positioned lengthways to the face section.

Slide face section with concealed fixing bracket into the neck of the plenum box. Turn the screwdriver until the tongue is in a crosswise position, then turn the screwdriver further to tighten the cheese-head screw. Please check that this screw is tight! Dismantling is carried out by reversing the procedure.

Figure 3

The volume control damper can be adjusted from the front face of the diffuser. To this end, adjust the air control blade below the spigot until the butterfly damper can be adjusted using a screwdriver or rod (max. diameter 3.5 mm, length up to approx. 230 mm, depending on neck extension).

Figure 4

When the slot diffusers are installed in linear configuration, the face sections are aligned by inserting the supplied alignment pins and/or fish plates. The alignment pins and fish plates (2 per section) are first fitted on one side and then slid approximately half way into the other face section (see also page 6).

Figure 1

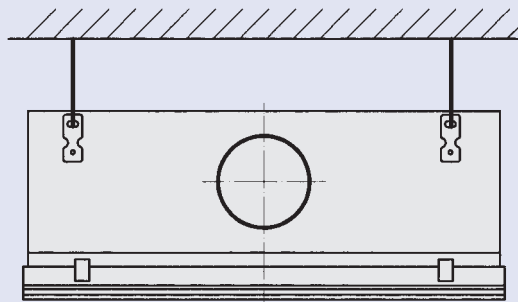
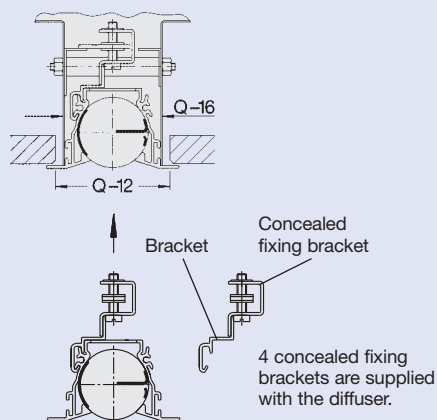

Figure 2 Ceiling void length: $L_1 + 12$



Note: On variants with fitted end caps, 1 cap per slot should be removed to enable fitting of the concealed fixing bracket.

Figure 3

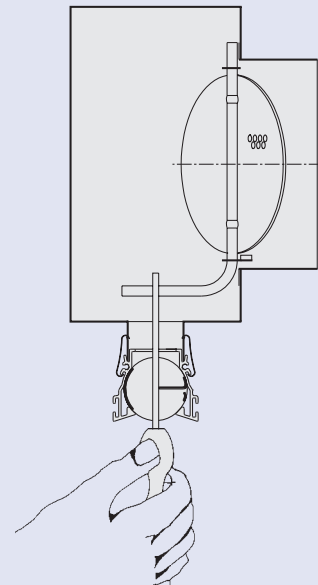
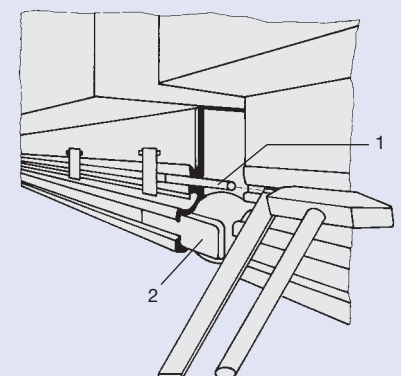

Figure 4



1 Alignment pin
2 Fish plate

Nomenclature

\dot{V}	in l/s · m:	Volume flow per unit length
\dot{V}	in m ³ /h · m:	Volume flow per unit length
\dot{V}_t	in l/s:	Total volume flow
\dot{V}_t	in m ³ /h:	Total volume flow
A	in m:	Spacing between two diffusers
H ₁	in m:	Spacing between ceiling and occupied zone
H _{1 max}	in m:	Maximum penetration depth when heating
L	in m:	Distance from diffuser L = A/2 + H ₁ or L = X + H ₁
\bar{v}_{H1}	in m/s:	Time average air velocity between two diffusers at distance H ₁
\bar{v}_L	in m/s:	Time average air velocity at wall at distance L
v _{eff}	in m/s:	Effective jet velocity
Δ t _Z	in K:	Temperature difference between supply air and room air
Δ t _L	in K:	Difference between room temperature and core temperature at distance L
Δ t _{H1}	in K:	Difference between core temperature and room temperature at distance H ₁
Δ p _t	in Pa:	Total pressure drop
L _{WA}	in dB(A):	A-weighted sound power level
L _{W NC}	:	NC rating of sound power level
L _{W NR}	:	L _{W NR} = L _{W NC} + 2
L _{pA} , L _{pNC}	:	A weighting and NC rating respectively of room sound pressure level L _{pA} ≈ L _{WA} - 8 dB L _{pNC} ≈ L _{W NC} - 8 dB
Δ L	in dB/oct.:	Relative sound power level with respect to L _{WA}
L _W	in dB/oct.:	Octave band sound power level of flow generated noise L _W = L _{WA} + Δ L

Effective Jet Velocity

\dot{V}_t in l/s

$$v_{\text{eff}} = \frac{\dot{V}_t}{s_{\text{eff}} \cdot L_1 \cdot 1000} \quad [\text{m/s}]$$

L₁ = Length of slot diffuser in m

\dot{V}_t in m³/h

$$v_{\text{eff}} = \frac{\dot{V}_t}{s_{\text{eff}} \cdot L_1 \cdot 3600} \quad [\text{m/s}]$$

Effective slot width

Air discharge	Horizontal	Angled
s _{eff} in m	0.0092	0.0061

Example

Data given:

VSD50-1; Air discharge alternating angled

Slot length $L_1 = 1500$ mm

Total volume flow $\dot{V}_t = 45$ l/s

Spigot diameter $D = 158$ mm

Required: Sound power level of flow generated noise L_w

Octave band centre frequency in Hz	63	125	250	500	1000	2000	4000	8000
L_{WA} in dB	33	33	33	33	33	33	33	33
L in dB	0	2	7	-4	-11	-18	-29	-36
L_w in dB	33	35	40	29	22	15	4	-3

Diagram 2: Sound power level and pressure drop

$$\Delta p_t = 10 \text{ Pa} \cdot 1.5 = 15 \text{ Pa}$$

$$L_{WA} = 25 \text{ dB(A)} + 5 = 33 \text{ dB(A)}$$

Effective jet velocity v_{eff} :

$$v_{eff} = \frac{\dot{V}_t}{s_{eff} \cdot L_1 \cdot 1000} = \frac{45}{0.0061 \cdot 1.5 \cdot 1000} = 4.9 \text{ m/s}$$

Relative Spectra ΔL for Damper Angle 0°

Type	Length mm	Effective jet velocity v_{eff} m/s	Octave band centre frequency in Hz							
			63	125	250	500	1000	2000	4000	8000
VSD50-1	600	2	12	7	7	-6	-26	-44	-46	-50
	1050		10	3	8	-10	-26	-38	-43	-47
	1500		9	3	8	-7	-23	-37	-42	-48
	600	3	8	7	7	-4	-20	-34	-35	-38
	1050		5	3	8	-7	-20	-29	-33	-38
	1500		6	3	7	-5	-17	-28	-33	-43
	600	5	1	6	6	-3	-13	-22	-28	-32
	1050		-1	3	7	-5	-12	-19	-28	-34
	1500		0	2	7	-4	-11	-18	-29	-36
	600	7	-4	5	5	-2	-9	-14	-26	-29
	1050		-6	2	6	-4	-8	-14	-30	-36
	1500		-4	0	5	-3	-8	-13	-30	-33
VSD50-2	600	2	12	7	7	-6	-25	-42	-44	-47
	1050		10	3	8	-9	-25	-37	-42	-47
	1500		10	4	7	-6	-21	-34	-40	-47
	600	3	8	7	7	-4	-19	-32	-34	-38
	1050		5	4	8	-7	-18	-28	-32	-37
	1500		6	3	7	-5	-16	-26	-31	-40
	600	5	1	6	6	-3	-12	-20	-27	-33
	1050		-2	3	7	-4	-11	-18	-29	-34
	1500		0	2	6	-3	-10	-16	-28	-35
	600	7	-4	5	5	-2	-8	-13	-25	-29
	1050		-7	2	5	-4	-7	-13	-30	-34
	1500		-4	0	5	-3	-7	-11	-30	-33

Acoustic Data

Correction to diagram 1: Damper setting

D = 123 mm		Air discharge horizontal			Air discharge angled		
Damper angle		0°	45°	90°	0°	45°	90°
L ₁ = 600	Δp _t	x 1	x 1.2	x 1.8	x 1.7	x 1.8	x 2.6
	L _{WA}	-	+ 1.0	-	+ 7.0	+ 6.0	-
	L _{WNC}	-	+ 1.0	-	+ 8.0	+ 6.0	-
L ₁ = 1050	Δp _t	x 1	x 1.4	x 3.1	x 1.6	x 1.9	x 3.6
	L _{WA}	-	+ 1.0	-	+ 5.0	+ 5.0	-
	L _{WNC}	-	+ 1.0	-	+ 6.0	+ 6.0	-
L ₁ = 1500	Δp _t	x 1	x 1.5	x 4.1	x 1.4	x 1.8	x 4.3
	L _{WA}	-	+ 1.0	-	+ 4.0	+ 3.0	-
	L _{WNC}	-	+ 1.0	-	+ 5.0	+ 4.0	-

Correction to diagram 2: Damper setting

D = 158 mm		Air discharge horizontal			Air discharge angled		
Damper angle		0°	45°	90°	0°	45°	90°
L ₁ = 600	Δp _t	x 1	x 1.1	x 1.4	x 1.6	x 1.7	x 1.9
	L _{WA}	-	-	-	+ 6.0	+ 6.0	-
	L _{WNC}	-	-	-	+ 5.0	+ 5.0	-
L ₁ = 1050	Δp _t	x 1	x 1.3	x 2.1	x 1.7	x 1.8	x 2.5
	L _{WA}	-	+ 1.0	-	+ 6.0	+ 5.0	-
	L _{WNC}	-	-	-	+ 6.0	+ 6.0	-
L ₁ = 1500	Δp _t	x 1	x 1.3	x 2.8	x 1.5	x 1.8	x 3.2
	L _{WA}	-	+ 1.0	-	+ 5.0	+ 4.0	-
	L _{WNC}	-	+ 1.0	-	+ 5.0	+ 4.0	-

Correction to diagram 3: Damper setting

D = 158 mm		Air discharge horizontal			Air discharge angled		
Damper angle		0°	45°	90°	0°	45°	90°
L ₁ = 600	Δp _t	x 1	x 1.3	x 2.0	x 1.7	x 2.0	x 2.5
	L _{WA}	-	+ 1.0	-	+ 7.0	+ 7.0	-
	L _{WNC}	-	+ 1.0	-	+ 8.0	+ 8.0	-
L ₁ = 1050	Δp _t	x 1	x 1.4	x 3.2	x 1.5	x 1.8	x 3.8
	L _{WA}	-	+ 1.0	-	+ 4.0	+ 4.0	-
	L _{WNC}	-	+ 1.0	-	+ 5.0	+ 5.0	-
L ₁ = 1500	Δp _t	x 1	x 1.6	x 4.4	x 1.4	x 1.9	x 4.7
	L _{WA}	-	+ 1.0	-	+ 3.0	+ 3.0	-
	L _{WNC}	-	+ 1.0	-	+ 4.0	+ 4.0	-

Correction to diagram 4: Damper setting

D = 198 mm		Air discharge horizontal			Air discharge angled		
Damper angle		0°	45°	90°	0°	45°	90°
L ₁ = 600	Δp _t	x 1	x 1.2	x 1.8	x 1.8	x 1.9	x 2.4
	L _{WA}	-	+ 1.0	-	+ 6.0	+ 7.0	-
	L _{WNC}	-	-	-	+ 7.0	+ 8.0	-
L ₁ = 1050	Δp _t	x 1	x 1.3	x 2.8	x 1.6	x 1.8	x 3.4
	L _{WA}	-	+ 1.0	-	+ 5.0	+ 5.0	-
	L _{WNC}	-	+ 1.0	-	+ 6.0	+ 6.0	-
L ₁ = 1500	Δp _t	x 1	x 1.4	x 3.6	x 1.5	x 1.8	x 4.2
	L _{WA}	-	+ 2.0	-	+ 5.0	+ 4.0	-
	L _{WNC}	-	+ 2.0	-	+ 6.0	+ 5.0	-

1 Sound power level and pressure drop VSD50-1; D = 123 mm

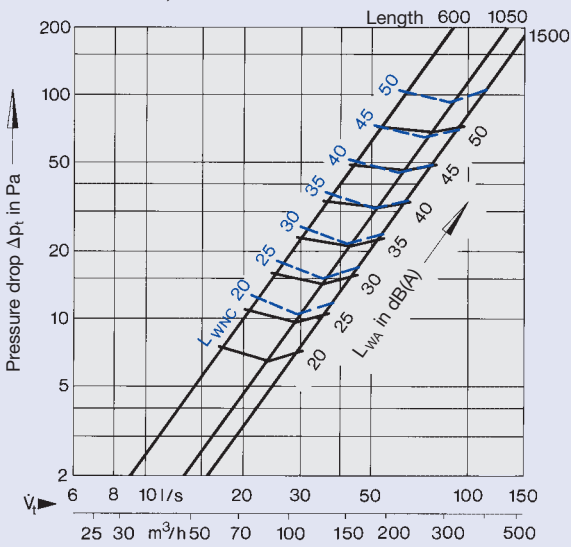

3 Sound power level and pressure drop VSD50-2; D = 158 mm

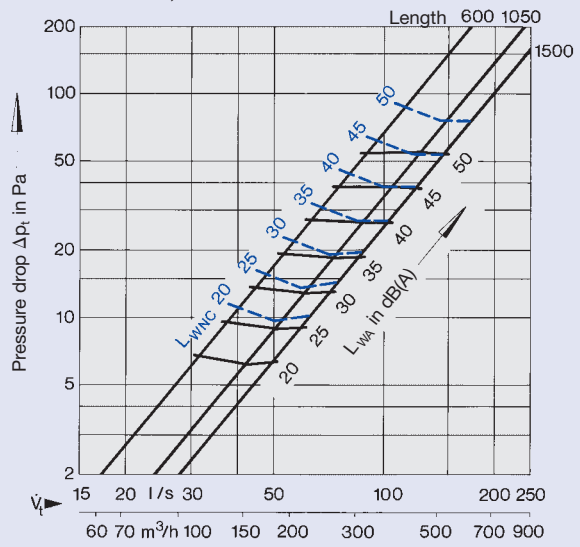

2 Sound power level and pressure drop VSD50-1; D = 158 mm

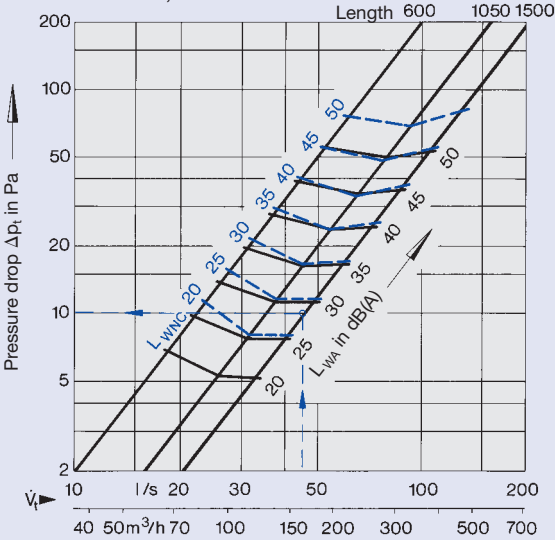

4 Sound power level and pressure drop VSD50-2; D = 198 mm

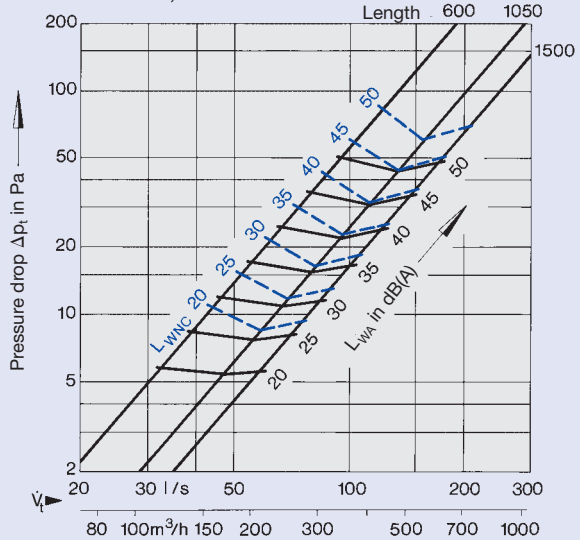

Aerodynamic Data

Air Discharge: Horizontal, One or Two Directions

5 Air velocity between two diffusers and at wall

$H_1 = 1.0 \ 1.2 \ 1.6 \ 2.0 \text{ m}$

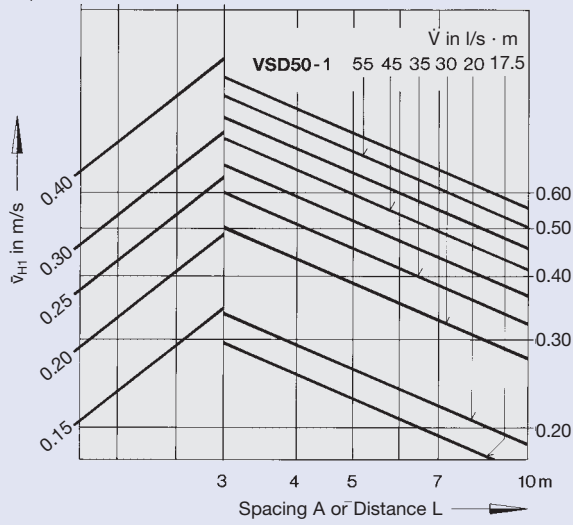

$$\dot{V} \text{ [m}^3\text{/h]} = \dot{V} \text{ [l/s]} \times 3.6$$

Diffuser Layout

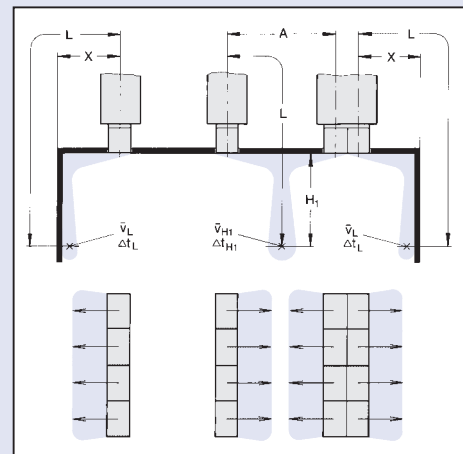

6 Air velocity between two diffusers and at wall

$H_1 = 1.0 \ 1.2 \ 1.6 \ 2.0 \text{ m}$

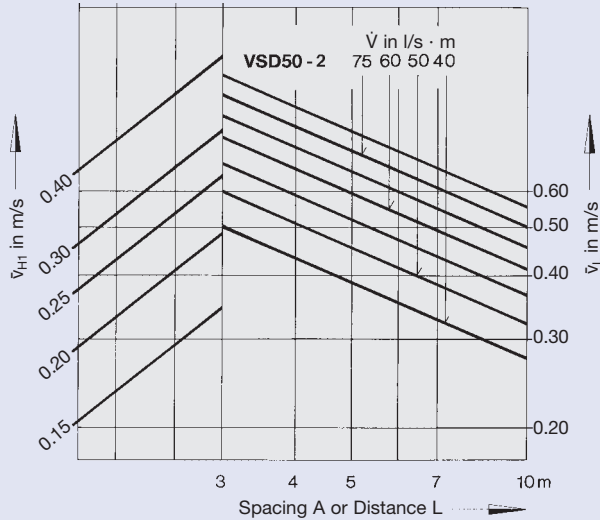

7 Temperature quotient

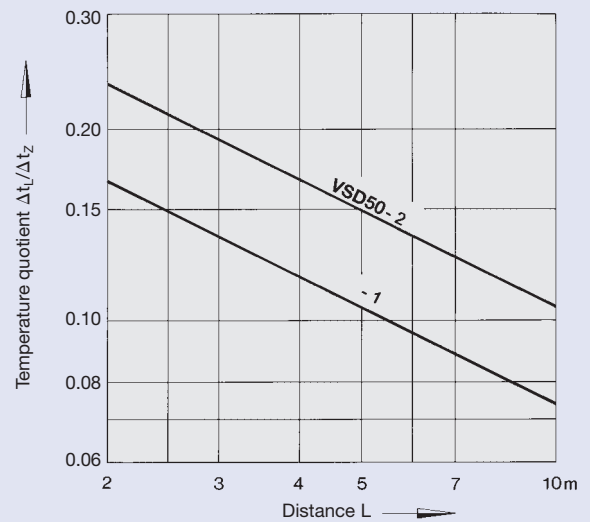

Aerodynamic Data

Air Discharge: Alternating Horizontal

Example

Data given:

VSD50-1; air discharge: alternating horizontal

Volume flow per unit length $\dot{V} = 30 \text{ l/s} \cdot \text{m}$

Supply air temperature differential horizontal, cooling $\Delta t_z = -10 \text{ K}$

Spacing between diffusers $A = 1.8 \text{ m}$

Distance between ceiling and occupied zone $H_1 = 1.2 \text{ m}$

Distance between diffuser centre line and wall $X = 2.4 \text{ m}$

Diagram 8:

$$\bar{v}_{H1} = 0.11 \text{ m/s}$$

Diagram 9:

$$L = X + H_1 = 2.4 + 1.2 = 3.6 \text{ m}$$

$$\bar{v}_L = 0.23 \text{ m/s}$$

Diagram 10:

$$L = A/2 + H_1 = 0.9 + 1.2 = 2.1 \text{ m}$$

$$\Delta t_L / \Delta t_z = 0.082$$

$$\Delta t_L = 0.082 \times (-10) \text{ K}$$

$$\Delta t_L = -0.82 \text{ K}$$

$$\text{At } L = X + H_1 = 3.6 \text{ m; } \Delta t_L / \Delta t_z = 0.062;$$

$$\Delta t_L \approx -0.6 \text{ K}$$

Air velocity between two diffusers

Air velocity at the wall

Temperature quotient

8 Air velocity between two diffusers

$H_1 = 1.0 \ 1.2 \ 1.6 \ 2.0 \text{ m}$

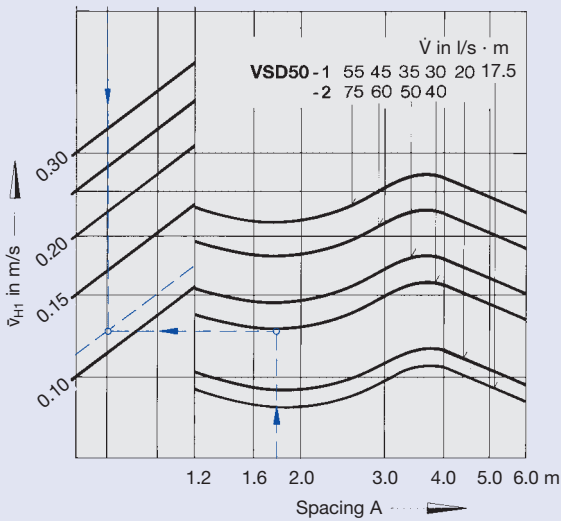

Diffuser Layout

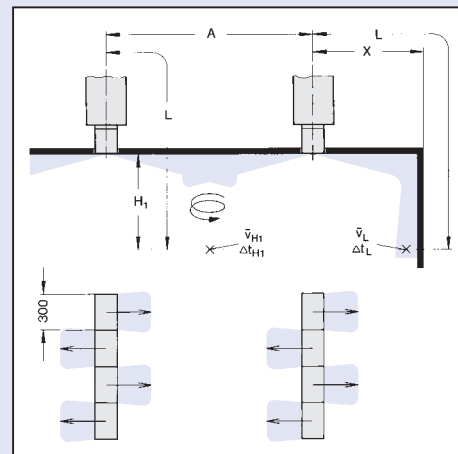

9 Air velocity at the wall

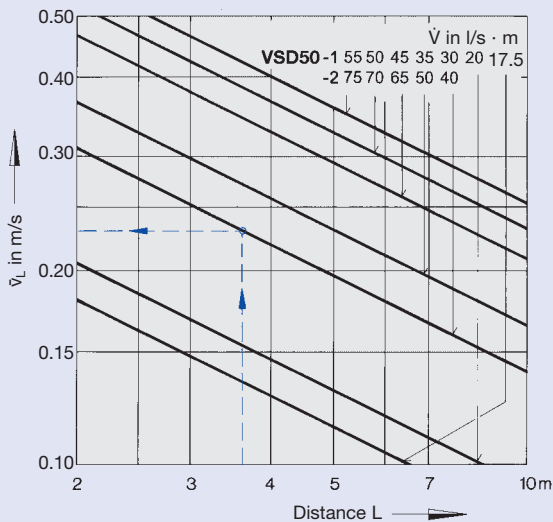

10 Temperature quotient

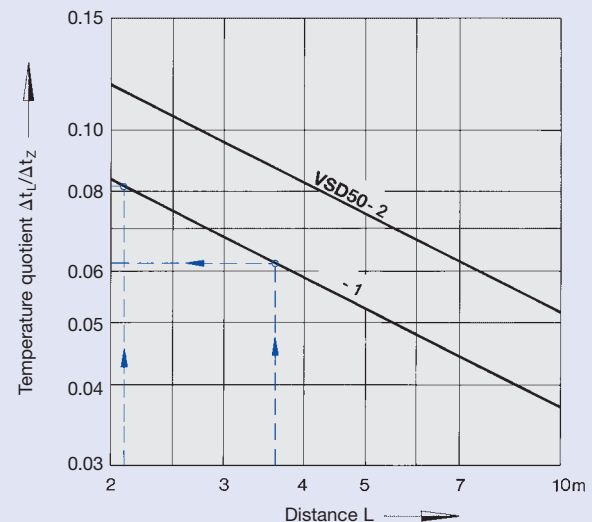

Aerodynamic Data

Air Discharge: Alternating Angled

Example

Data given:

VSD50-1; air discharge: alternating angled

Volume flow per unit length $\dot{V} = 30 \text{ l/s} \cdot \text{m}$

Supply air temperature differential $\Delta t_z = -8 \text{ K}$
approx. $+8 \text{ K}$

Spacing between diffusers $A = 2.4 \text{ m}$

Distance between ceiling and occupied zone $H_1 = 1.0 \text{ m}$

Diagram 11:
 $\bar{v}_{H1} = 0.22 \text{ m/s}$

Air velocity

Diagram 12:
Temperature quotient cooling

$\Delta t_{H1}/\Delta t_z = 0.057$
 $\Delta t_{H1} = 0.057 \times (-8 \text{ K}) \approx -0.5 \text{ K}$
For heating $\Delta t_z = +8 \text{ K}$

Diagram 13:
Maximum penetration depth for heating

$H_{1\text{max}} \approx 1.2 \text{ m}$

11 Air velocity

$H_1 = 1.0 \quad 1.2 \quad 1.6 \quad 2.0 \text{ m}$

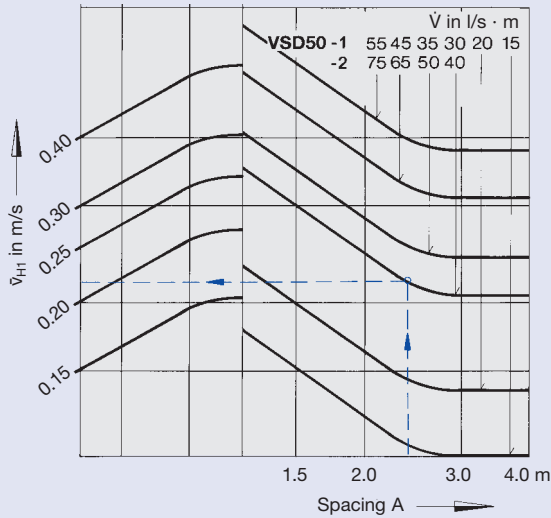

$$\dot{V} [\text{m}^3/\text{h}] = \dot{V} [\text{l/s}] \times 3.6$$

Diffuser Layout

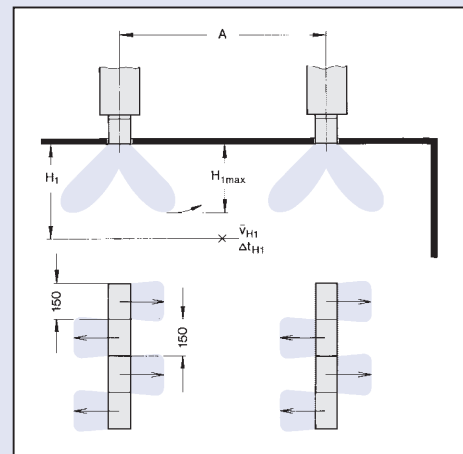

12 Temperature quotient - Cooling

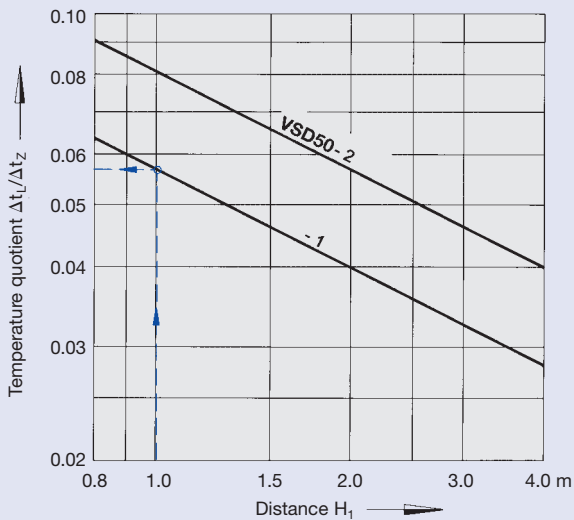

13 Maximum penetration depth for heating

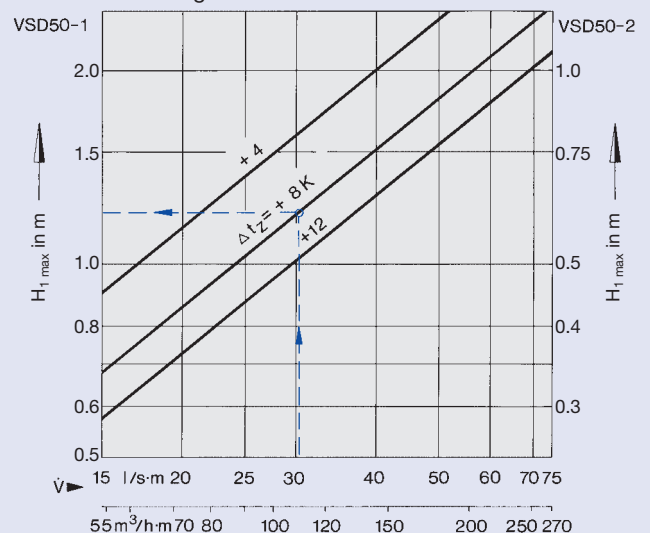

Order Details

Specification Text

Adjustable slot diffusers with aesthetically designed face sections, suitable for installation in suspended ceiling systems, comprising the diffuser face in 1- or 2-slot configuration, optionally without edge flange (000) or with integral edge flange (B00). End caps either as end plates or end angles, with incorporated air control blades, which are set at the factory but can be adjusted by the user at any time to enable adaption to the prevailing conditions. The slot diffuser has a variable neck length and the diffuser face can optionally be fitted to the plenum box on site. The plenum box is optionally available with a 20 mm thick inner lining, faced on one side with scrim, with circular side entry spigot with or without sealing lip and four suspension

points for suspension of the complete assembly from the ceiling slab, optionally with volume control damper which is adjustable on the face of the diffuser.

Materials:

Diffuser face and end caps consist of extruded aluminium sections, natural anodised finish E6-C-0 or powder-coated in RAL colours. The air control blades are produced in black plastic (polystyrene) as standard, similar to RAL 9005, or on request in white (similar to RAL 9010). The plenum box consists of sendzimir galvanised sheet steel, lining in mineral wool faced on one side with scrim, sealing lip in rubber.

Order Code

State variable y dimension ⁴⁾

These codes do not require to be stated for standard variants

VSD50-1-AK-M-L / **900 x 123 x y** / **C1** / **0** / **P1** / **RAL 9016** / **WS**

No. of slots "n" $\left. \begin{matrix} 1 \\ 2 \end{matrix} \right\}$

Plenum box

- Clip fix AK
- Clip fix DK
- Concealed slot fixture AS
- Concealed slot fixture with internal lining DS
- Offset 90° mitre AA
- Face section E
- Face section F

Volume control damper M ¹⁾

Spigots with sealing lip L ¹⁾

600	
750	
900	
1050	
1200	
1350	
1500	
1650 ³⁾	
1800	
1950	
L₁(mm)	

123	1
158	1 + 2
198	2
∅ D(mm)	n

HL Horizontal left

HR Horizontal right

WH Alternating horizontal (standard) *

WS Alternating angled

* see pages 2 and 3

State colour

0 Standard finish E6-C-0

P1 Powder-coated to RAL 9006 (GE 30%) ⁵⁾ other colours to RAL... (GE 70%) ⁵⁾

Note
Air control blades as standard are made of black plastic (similar to RAL 9005), on request white plastic (similar to RAL 9010). Please state in the supplementary text.

000 Without edge flange ²⁾

B00 Integral edge flange

See table: End angles/plates – supplied fixed –

0 No end cap

Order code for pairs of end angles/end plates – supplied loose – – Please order separately –		
Type	000	B00
End plate	VSD50-*-EP/000	VSD50-*-EP/B00
End angle	VSD50-*-EW/000	VSD50-*-EW/B00
* 1-...2 slots		

End angles/end plates – supplied fixed –		
	Edge flange	Both ends
End angles	000	C1
	B00	C2
End plates	000	C5
	B00	C6

Order Example

Make : TROX
 Type: VSD50-1-AK-M-L/900x123/C1/B00/P1/RAL9016/WS
 Suppl. text: Air control blades white, similar to RAL 9010